

23.88
23.58
24.46

24.65

24.79

24.84

25.45

25.96
25.88

26.36
26.14

muro bloque y piedra

25m

26m

límites de retranqueos

Cubierta plana de hormigón aligerado con pendiente mínima del 2%. Acabado: Membrana continua con fibra de vidrio tipo Icooper o similar en gris. Juntas de dilatación cada 5x5m máximo.

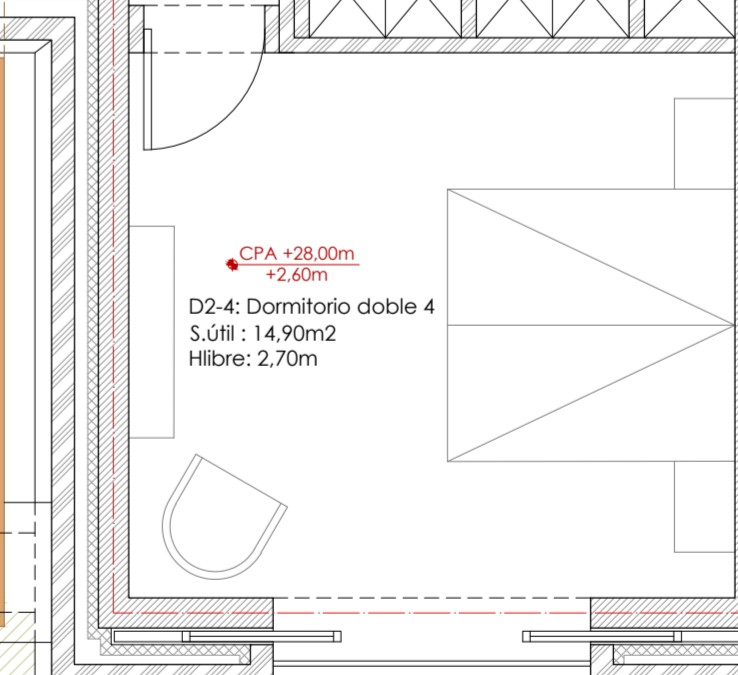
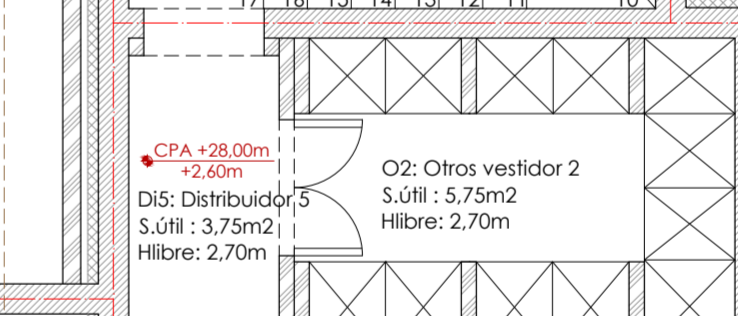
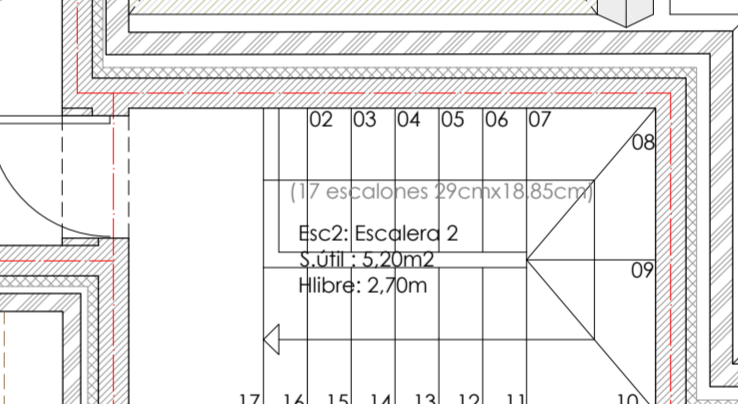
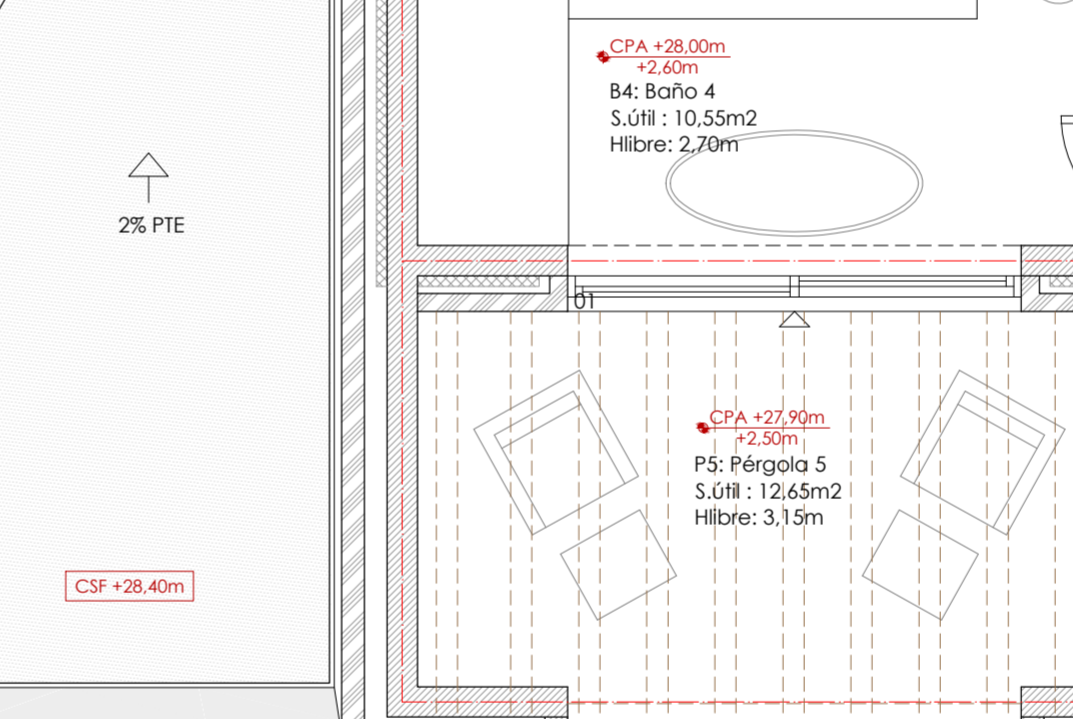
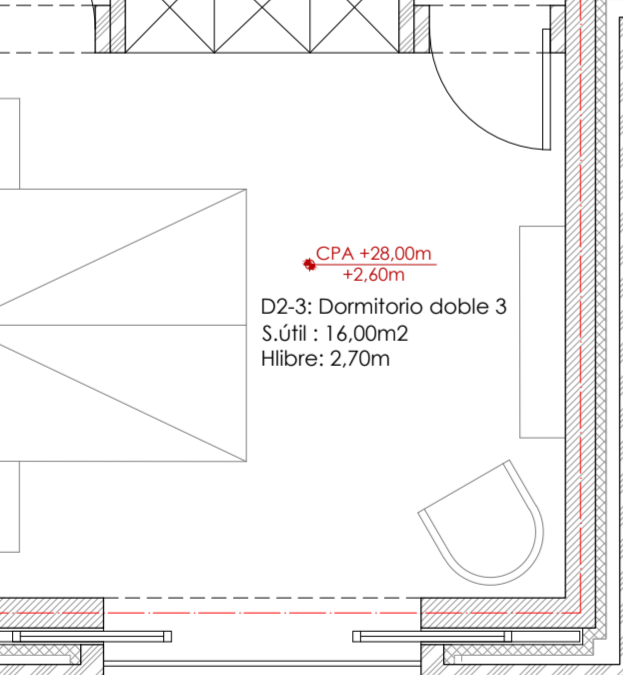
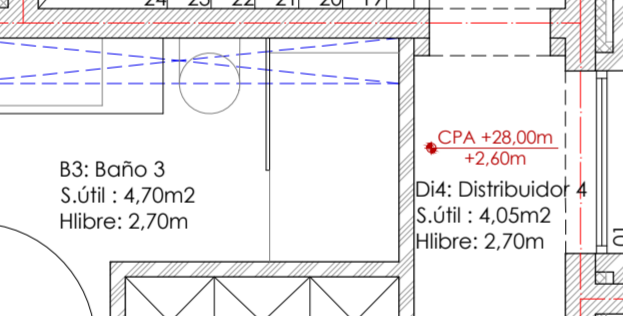
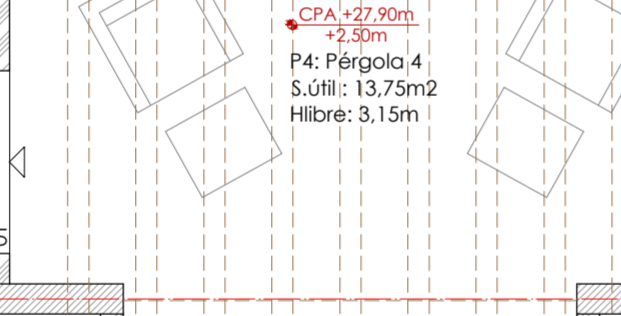
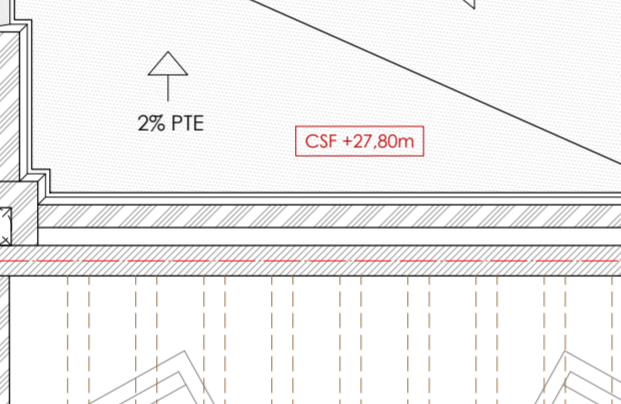
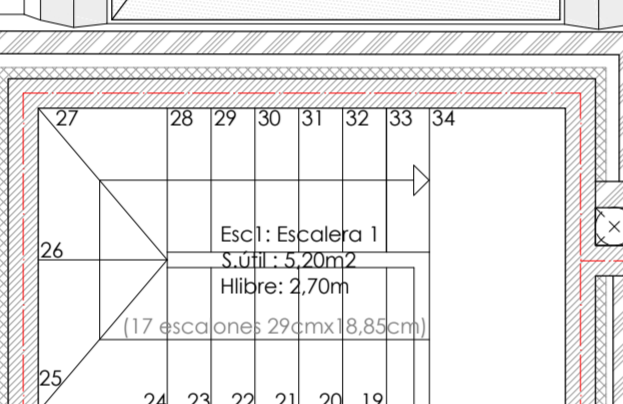
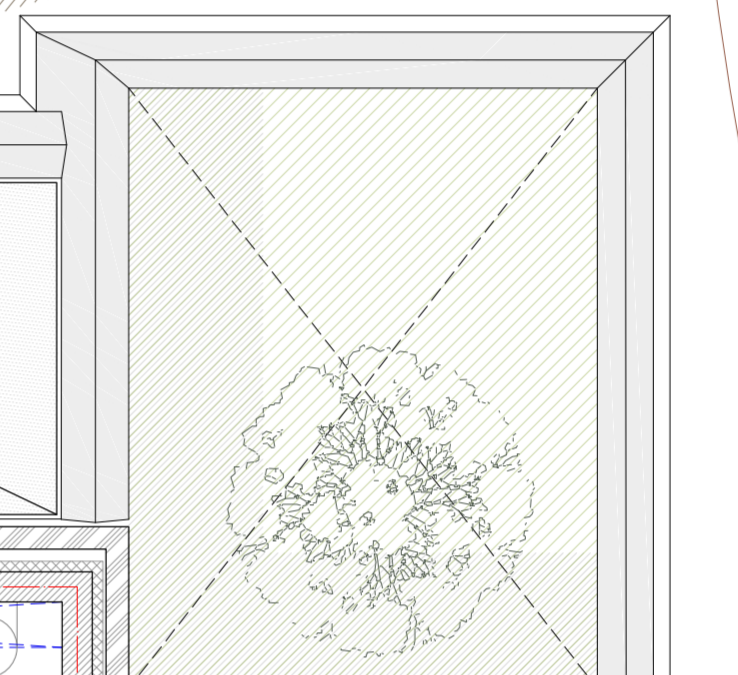
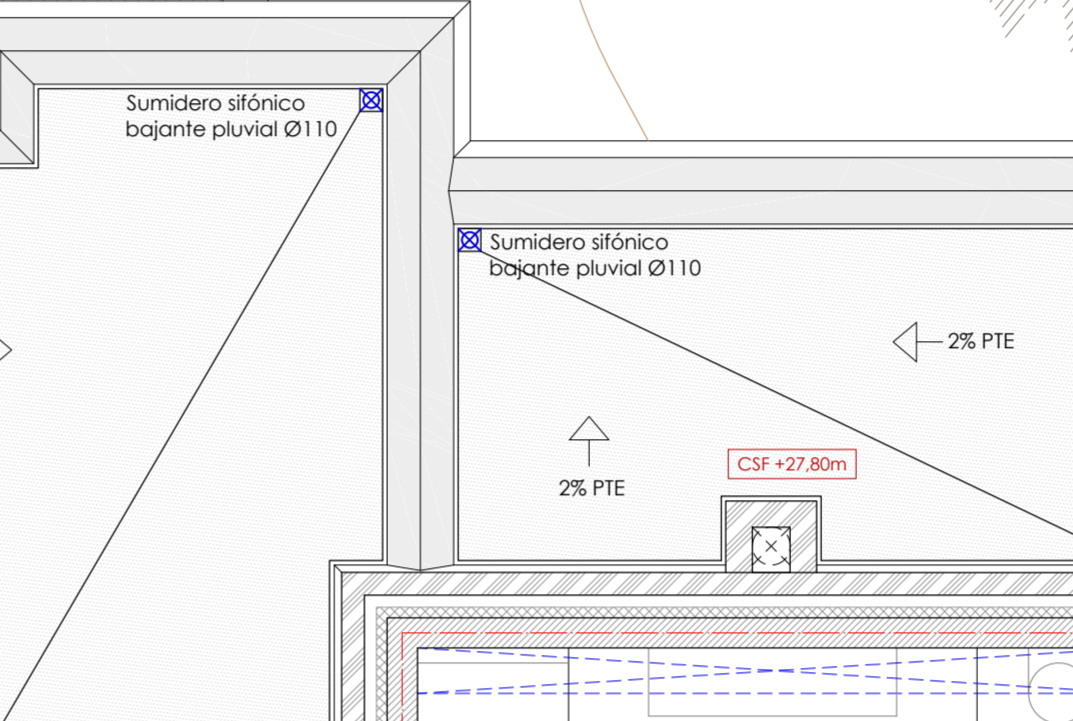
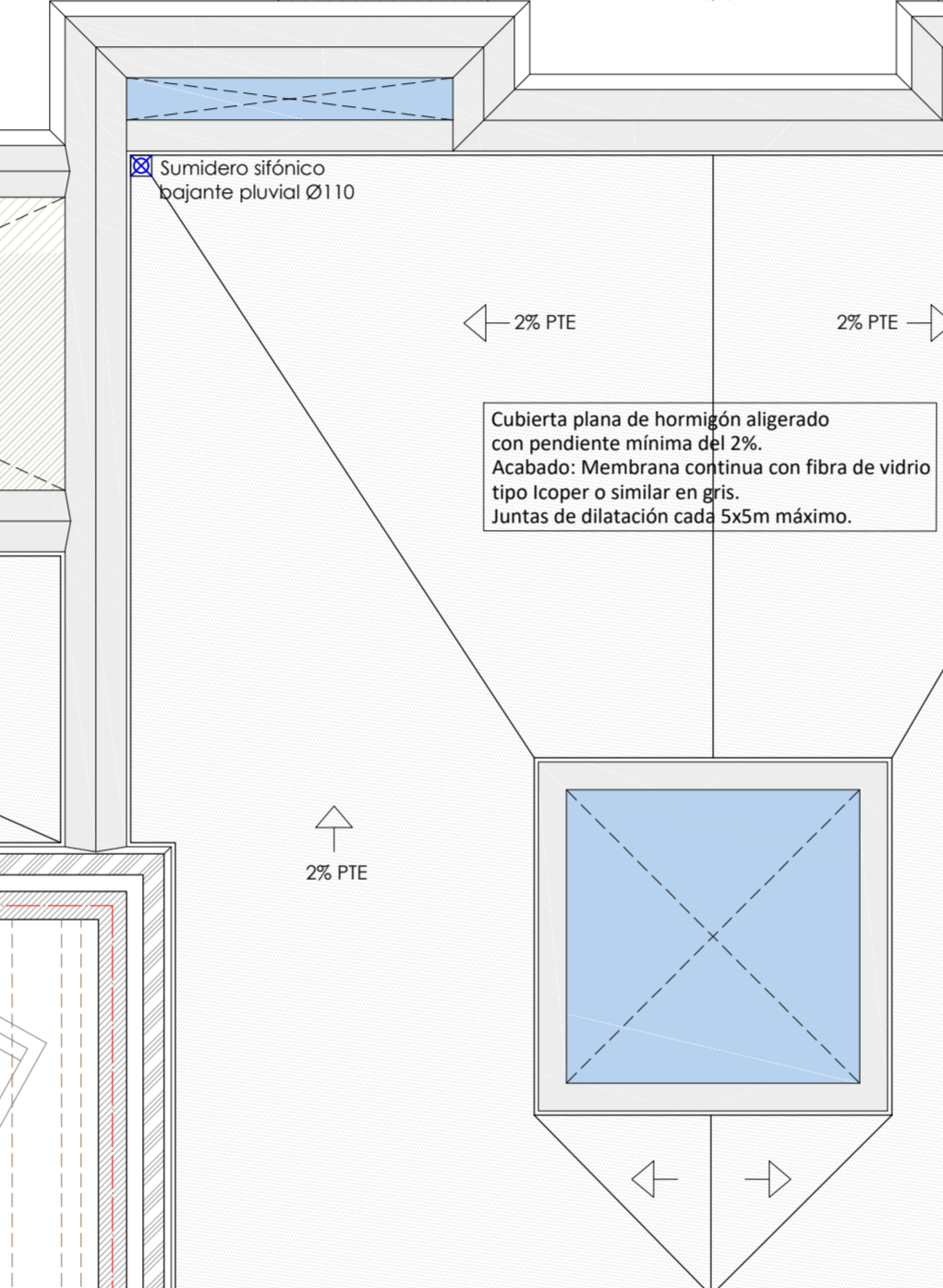
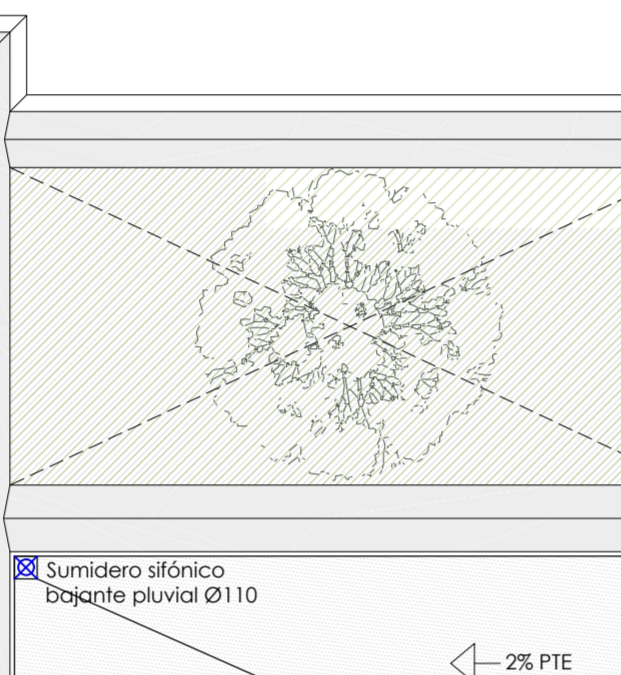
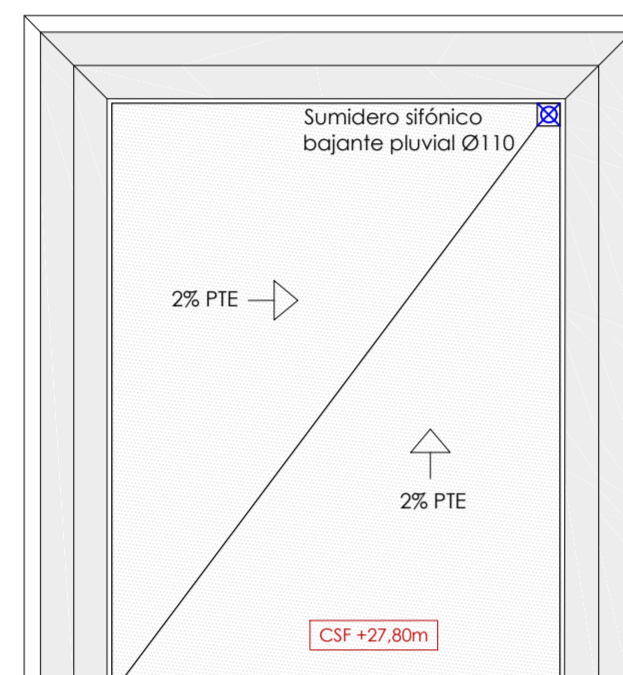

CPA +24.18m
-1.22m

CPA +24.65m
-0.75m

CPA +23.64m
-1.76m

CPA +23.64m
-1.76m

24m

23m

26m